



User manual NANO Digital Input POE



Soft >= 1.0

Dear Customer!

INVEO s.c.
ul. Rzemieślnicza 21
43-340 Kozy
tel: +48 33 444 65 87
www.inveo.com.pl
info@inveo.com.pl

Thank you very much for choosing our product. Please carefully read this user manual as it contains most appropriate ways of dealing with this device, taking into account the basic principles of safety and maintenance. Please also keep the user guide that you can use it during subsequent use.

Manufacturer Liability!

The manufacturer is not liable for any damage caused by improper or incompatible use of this device, as well for any faults to the device resulting from improper use.

Contents:

- 1 PRELIMINARY INFORMATION.....4**
- 2 DEVICE DESCRIPTION.....5**
- 3 WARRANTY AND LIABILITY OF THE MANUFACTURER.....5**
- 4 SAFETY GUIDELINES.....6**
 - 4.1 POWER SUPPLY.....6
 - 4.2 STORAGE, WORKING ENVIRONMENT AND TRANSPORTATION.....6
 - 4.3 INSTALLATION AND USE OF THE MODULE.....6
 - 4.4 UTILISATION OF THE MODULE.....6
- 5 MODULE DESCRIPTION.....7**
 - 5.1 GENERAL FEATURES.....7
 - 5.2 TECHNICAL SPECIFICATION:.....7
 - 5.3 MODULE INPUT/OUTPUT TERMINAL DESCRIPTION.....8
- 6 MODULE CONFIGURATION.....9**
 - 6.1 CHANGING THE PC SETTING FOR MODULE CONFIGURATION.....9
 - 6.2 INPUT READOUT.....11
 - 6.3 ACCESS CONFIGURATION.....11
 - 6.4 CONFIGURATION OF THE INPUT CHANNEL.....13
 - 6.5 TCP/IP COMMUNICATION.....13
 - 6.6 TCP FRAMES FORMAT.....14
 - 6.7 SNMP CONFIGURATION.....15
 - 6.8 MANAGING THE MODULE USING WINDOWS COMMAND LINE SOFTWARE.....16
 - 6.9 MANAGING THE MODULE USING LINUX COMMAND LINE SOFTWARE.....18
 - 6.10 MANAGING THE MODULE USING MODBUS TCP.....19
 - 6.11 COMMUNICATION VIA THE MQTT INVEO PROTOCOL.....19
 - 6.12 COMMUNICATION WITH MODULE USING HTTP.....20
 - 6.13 COMMUNICATION PROTOCOL DESCRIPTION.....23
 - 6.14 COMMUNICATION WITH MODULE FROM OUTSIDE NETWORK.....24
- 7 CHECKING THE IP ADDRESS.....25**
- 8 DHCP.....25**
- 9 RESTORING FACTORY DEFAULTS.....25**
- 10 FIRMWARE UPDATE.....26**
- NOTES.....27**

1 Preliminary information

Before using the module please read the user manual carefully and follow the instructions contained within!

Description of visual symbols used in this user manual:



This symbol is responsible for reviewing the appropriate place in the user instructions, warnings and important information. Failure to follow warnings could cause injury or damage to the module.



Important information and guidelines.



Following this guidelines makes the use of the module easier.

Attention: The appearance of the screen shots shown in this manual may differ slightly from the actual work with the module. The differences may relate to the size and font type and size of symbols. There are no differences in the content of the information.

2 Device description

The NANO Digital Input device is used to read state of the input through LAN network. The readout can be done using www website, network protocols (HTTP get, Modbus TCP, SNMP, MQTT) TCP frame or software supplied by manufacturer.

3 Warranty and liability of the manufacturer



The manufacturer provides a 2-year warranty on the module. The manufacturer also provides post-warranty service for 10 years from the date of the introducing the module on the market. The warranty covers all defects in material and workmanship.

The manufacturer undertakes to comply with the contract of guarantee, if the following conditions are met:

- All repairs, alterations, extensions and device calibrations are performed by the manufacturer or authorized service,
- supply network installation meets applicable standards in this regard,
- device is operated in accordance with the recommendations outlined in this manual,
- device is used as intended.

The manufacturer assumes no responsibility for consequences resulting from improper installation, improper use of the module, not following this manual and the repairs of the module by individuals without permission.



This device doesn't contain serviceable parts. The repairs can be done only by manufacturers approved repair service.

4 Safety guidelines

The module has been constructed using modern electronic components, according to the latest trends in the global electronics.

In particular, much emphasis was placed on ensuring optimum safety and reliability of control.

The device has a housing with high quality plastic.

4.1 Power supply

The device is designed to supply 10-24V DC and PoE IEEE 802.3af.



4.2 Storage, working environment and transportation

The module has to be used in closed environments free from fumes and corrosive atmosphere.

Environmental conditions for storage:

- Temperature: -30°C to +60°C,
- Relative humidity: <90% (unacceptable condensation)
- Atmospheric pressure: 700 – 1060hPa.

Environmental conditions for use:

- Temperature: +10°C to +55°C,
- Relative humidity: 30% to 75%,
- Atmospheric pressure: 700 to 1060hPa.

4.3 Installation and use of the module



The module should be used following the guidelines shown in next part of the user manual.

4.4 Utilisation of the module

When it becomes necessary to liquidate the device (e.g. after the time of use), please contact the manufacturer or its representative, who are obliged to respond appropriately, e.g. collecting the module from the user. You can also ask the companies involved in utilization and / or liquidation of electrical or computer equipment. Under no circumstances should you place the device along with other garbage.

5 Module description

5.1 General features

Overall view of the module is shown on the picture below.



Module input can work as a pulse counter

There are several ways to communicate with the module:

- using built in WWW server via any web browser,
- windows / linux command line programs.
- MODBUS TCP protocol,
- SNMP protocol,
- HTTP protocol,
- MQTT Inveo protocol,
- User application – communication protocol available for user

NANO Digital Input module is equipped with LED display which displays actual state of input: **on** or **oFF**.

5.2 Technical specification:

Power supply voltage: 10-24VDC or PoE according to PoE IEEE 802.3af

Power consumption: 1.5 W

Ethernet 10Mbit

7-segment LED display red

Weight: 60g

Distensions: height: 27 mm; width: 74.6 mm; length: 50.1 mm

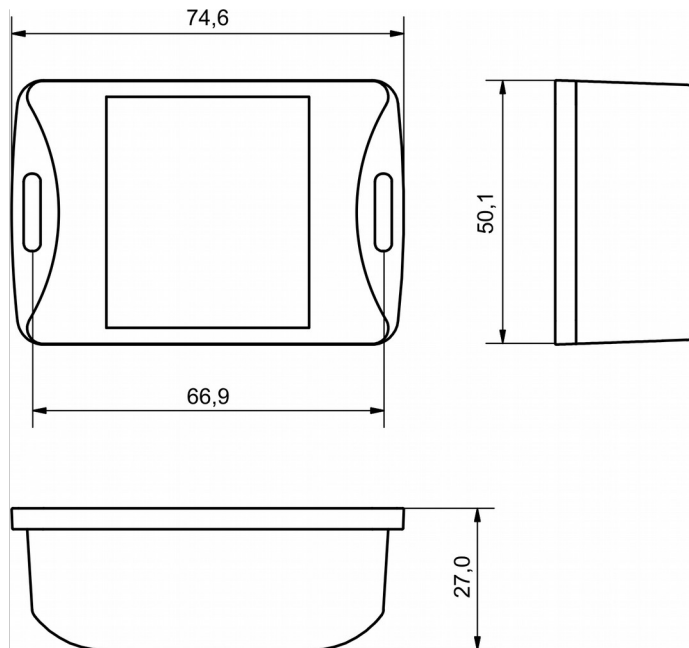

Input:

Input type - NO

Counter max value: 4 294 967 296

Max input frequency: 1000Hz

5.3 Module input/output terminal description

Module Nano Digital Input has two connection terminals:

- **LAN** - LAN connection and PoE IEEE 802.3af power supply
- **RESET** – switch used to enabling DHCP service, checking the current IP address and restoring the module to the factory settings.

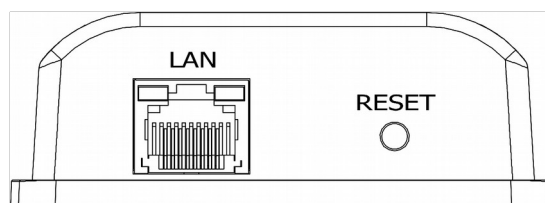

- **INPUT** – binary opto-isolated input
- **POWER** -power connector. An additional power connector used in the event of a PoE power failure. Supply voltage 12-24VDC.

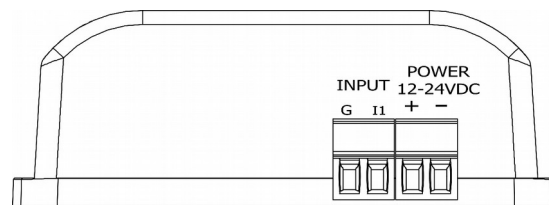

6 Module configuration

If using the module for the first time it is needed to configure it as shown below

6.1 Changing the PC setting for module configuration.

After connecting the module to the network there is a need to change the PC setting. In order to do that navigate to: Start->Control Panel->Network connections. Then right click on the current network connection and click „Properties”. The configuration screen as shown below should be visible on the screen:

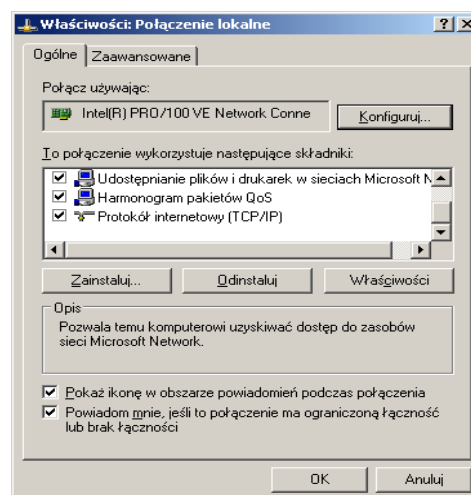

Choose the „Internet Protocol (TCP/IP)” and press „Properties”:

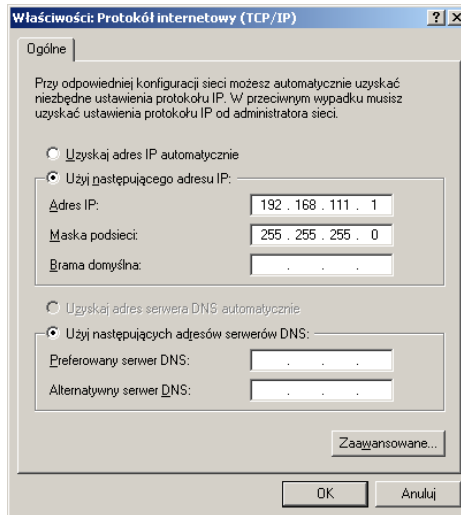

TCP/IP example settings

Tick the box „Use the following IP address” and enter:

IP address: **192.168.111.1**

Subnet mask: **255.255.255.0**

The rest of the setting can be left blank.

Press OK to accept the changes.

Start the web browser and enter the following address into address bar:

192.168.111.15. Then select the "NETWORK" menu

The default user name is „admin” with password „admin00”

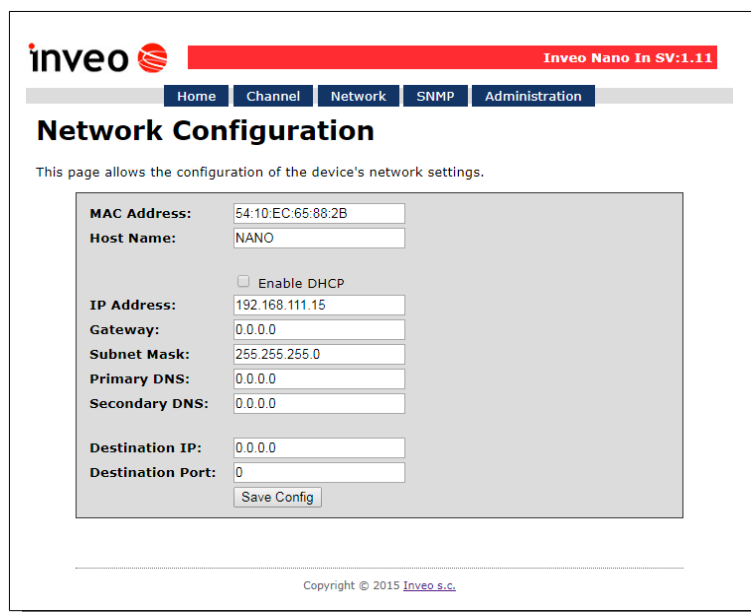

There are several fields used to configure the module network settings:

- MAC Address – MAC address of the module,

- Host Name – NETBIOS host name of the module,
- Enable DHCP – When this box is ticked the module will get its address from DHCP server,
- IP Address – IP address of the module – when configured manually,
- Gateway – Network gateway,
- Subnet Mask – Subnet mask of the module,
- Primary DNS, Secondary DNS – DNS servers addresses,
- Destination IP – Network address of the server that the module will connect to - optional,
- Destination Port – Network port of the server that the module can connect to.

After changing the configuration press the „Save Config” button.

6.2 Input readout.

The Home tab shows the current status of the input channel and the status of the pulse counter.

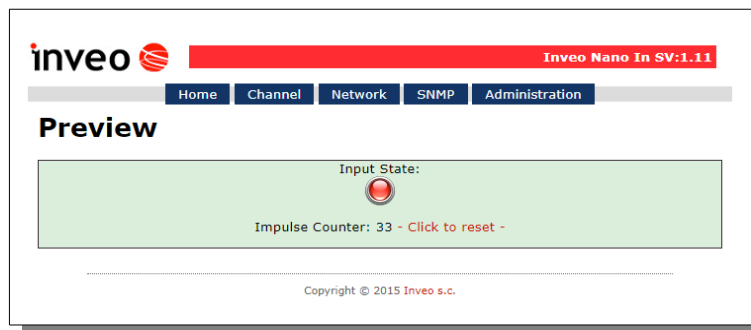

Input State icon show actual state of the input (red – inactive, green – active).

Impulse Counter impulses counted .

Click to reset – reset impulse counter

6.3 Access configuration

Web site used to configure the access to the module is shown below.

These settings allow for changing the access password and to enable/disable particular services.

The screenshot shows the 'Administration' page of the Inveo Nano In SV:1.11. The page has a navigation bar with links for Home, Channel, Network, SNMP, and Administration. The main heading is 'Administration', and a sub-heading states 'This page allows the configuration of the device's access settings.' The configuration form contains three password input fields: 'Current Password', 'New Password', and 'Re-type Password'. Below these are seven checkboxes, all of which are checked: 'Enable Program Access', 'Enable MODBUS TCP Protocol', 'Enable SNMP', 'Enable Destination Client', 'Enable MQTT Inveo [Show Info]', 'Enable Remote Network Config', and 'Enable TFTP Bootloader'. A 'Save Config' button is located at the bottom of the form. The footer of the page indicates 'Copyright © 2015 Inveo s.c.'

Changing the password

Enter old password into *Current Password* field.

Enter new password into *New Password* field and into *Re-type Password* field then press „Save Config” to save new passwords.

Enabling/disabling particular service

This function enables/disables different services. By enabling the tick box next to a service user can turn it on or off.

Module Access configuration

- **Enable Program Access** – access service by a computer program (Windows, Linux) and TCP / IP protocol operating on port 9761
- **Enable MODBUS TCP Protocol** – enables/disables access using MODBUS TCP protocol.
- **Enable SNMP** – enables/disables access using SNMP protocol.
- **Enable Destination client** – enables/disables connection service with a remote host
- **Enable MQTT Inveo** -enables/disables service sending data to the INVEO MQTT cloud
- **Enable Remote Network Config** – enables/disables service of remote change of network settings by the INVEO DISCOVERER program
- **Enable TFTP bootloader** – enables/disables bootloader mode

Warning:

TFTP Bootloader should be disabled during normal operation. Enabling should take place only before the software update.

6.4 Configuration of the input channel.

The module input configuration is carried out in the **Channel** tab.



The Client Mode field allows you to select the TCP frame format which will be sent to the address set in the tab Network Destination IP, Destination Port. The TCP frame is sent every 5 seconds and at each change of the output state.

After making changes, click the Save button.

6.5 TCP/IP communication

The NANO Digital Input module is able to send an input status to another module or to the server using the TCP protocol. This means that when a state of the input will change a message will be sent to another device that can react, for example, by activating a relay. The IP address of the device to which information is to be sent should be set in the tab **Network** Destination IP, Destination Port. The message is sent whenever an input status changes, and additional every 5 seconds.

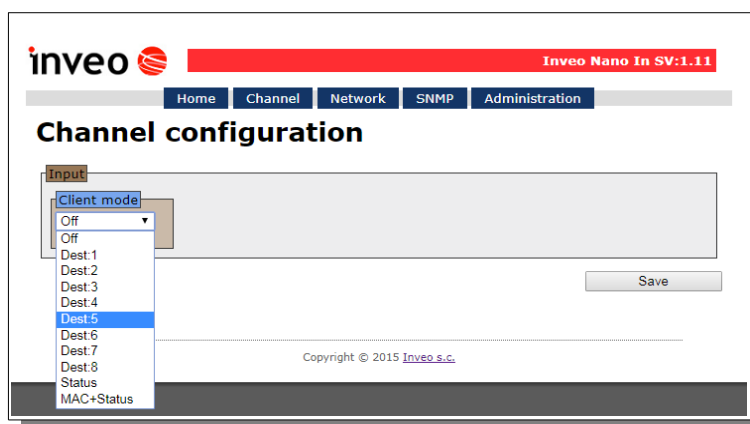

In the **Client mode** field, you can select the frame format:

- **Off** -sending frames disabled
- **Dest: 1..8** -sending TCP frames in the **format #1** (compatible with INVEO devices)
- **Status** -sending TCP frames in the **format #2**
- **MAC + Status** -sending TCP frames in the **format #3**

6.6 TCP frames format

Format #1

The frame in the format #1 is sent in binary form.

An example of a TCP frame sent with active input and **Dest:5** set

SOF	CMD	CH	F_ID	IN	!IN	CNT0	CNT1	CNT2	CNT3	CRC
0x0F	0x01	0x04	0xFF	0x01	0xFE	0x1E	0x00	0x00	0x00	0x30

An example TCP frame sent with inactive input and **Dest:5** set

SOF	CMD	CH	F_ID	IN	!IN	CNT0	CNT1	CNT2	CNT3	CRC
0x0F	0x01	0x04	0xFF	0x00	0xFF	0x1E	0x00	0x00	0x00	0x30

Calculation CRC:

CRC = (BYTE) SUM (SOF+CMD+CH+F_ID+IN+!IN+CNT0+CNT1+CNT2+CNT3)

Format #2

The frame #2 is sent as a string (STRING).

<INPUT STATE>[SPACE]<COUNTER>

- **INPUT STATE** -value 1 means active input, 0 means inactive input
- **COUNTER** – the counter state

HEX value				STRING
30	20	33	30	0 30

Format #3

The frame #3 is sent as a string (STRING).

<MAC>[SPACE]<INPUT STATE>[SPACE]<COUNTER>

- **MAC** -network address of the module
- **INPUT STATE** -value 1 means active input, 0 means inactive input
- **COUNTER** – the counter state

HEX value														STRING			
35	34	31	30	45	43	36	35	38	38	32	42	20	30	20	33	30	5410EC65882B 0 30

The TCP frame can be supported with your own software.

An example of using the netcat command for Linux:

User manual NANO Digital Input

26-04-2018

Format #1

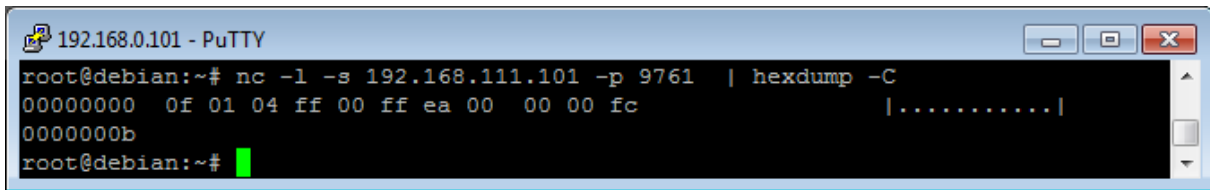

```
192.168.0.101 - PuTTY
root@debian:~# nc -l -s 192.168.111.101 -p 9761 | hexdump -C
00000000  0f 01 04 ff 00 ff ea 00  00 00 fc  |.....|
0000000b
root@debian:~#
```

Format #2

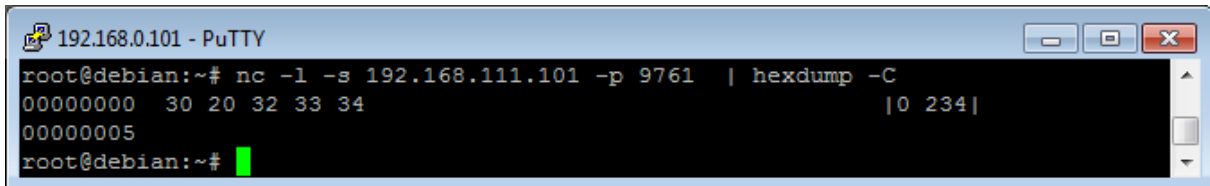

```
192.168.0.101 - PuTTY
root@debian:~# nc -l -s 192.168.111.101 -p 9761 | hexdump -C
00000000  30 20 32 33 34  |0 234|
00000005
root@debian:~#
```

Format #3

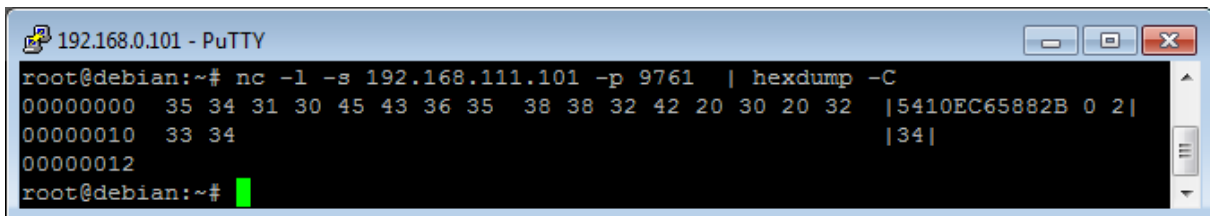

```
192.168.0.101 - PuTTY
root@debian:~# nc -l -s 192.168.111.101 -p 9761 | hexdump -C
00000000  35 34 31 30 45 43 36 35  38 38 32 42 20 30 20 32  |5410EC65882B 0 2|
00000010  33 34  |34|
00000012
root@debian:~#
```

6.7 SNMP configuration

The module is equipped with an SNMP v2c server.
To enable this feature go to Administration tab-> Enable SNMP.

SNMP protocol enables user to retrieve and set the output status and to read state of inputs and counters.

The MIB file describing the structure can be downloaded the SNMP tab.

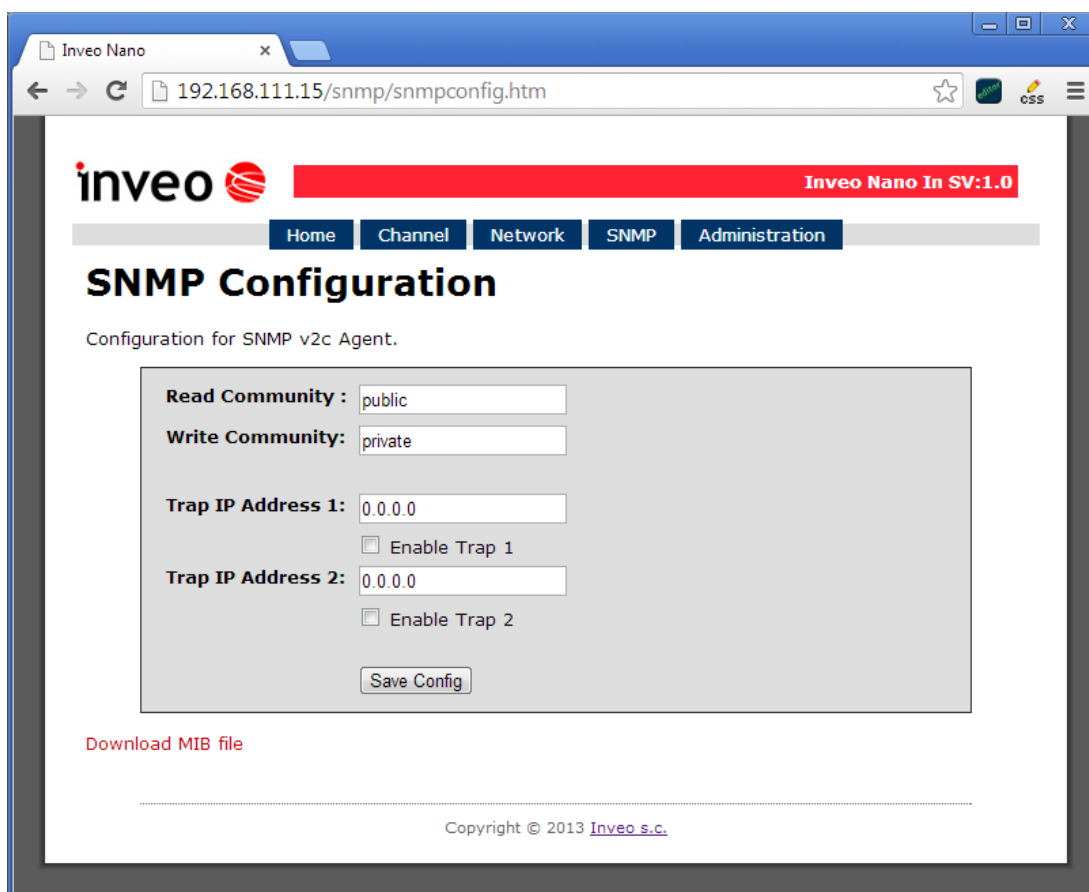

The basic parameters that can be read from the NANO Digital Input module can be found in the table:

Name	Format	OID
State of the input channel	INTEGER	.1.3.6.1.4.1.42814.14.3.3.1.0
State of the counter	INTEGER	.1.3.6.1.4.1.42814.14.3.4.1.0

The module allows sending TRAP messages when the input channel is changed. The destination address is entered in the fields **Trap IP Address 1** and **Trap IP Address 2**.

6.8 Managing the module using windows command line software

The module can be operated using windows command line software – the software is delivered with the module.

Syntax is as follows:

: TCPRel.exe [Parameters]

Parameter	Description
-in=1	Input number
-host=[HOST]	Module IP address
-port=[PORT]	Module Port number
-writecounter=0-4228250625	Set counter
-readcounter	Read counter
-verb	Enabled display of additional info
-stat	Displays current state of inputs/outputs

Examples:

Read input state module address 192.168.111.15 listening on port 9761:

```
TCPre1 -in=1 -host=192.168.111.15 -port=9761 -stat
```

Reset counter :

```
TCPre1 -host=192.168.111.15 -port=9761 -in=1 -writecounter=0
```

Set counter 1 to value of 123:

```
TCPre1 -host=192.168.111.15 -port=9761 -in=1 -writecounter=123
```

Read state of counter 1:

```
TCPre1 -host=192.168.111.15 -port=9761 -in=1 -readcounter
```

6.9 Managing the module using Linux command line software

The module can be configured using Linux command line software – the software is delivered with the module.

Syntax is as follows:

```
./TcpRel.exe [Parameters]
```

Parameter	Description
-i 1	Input number
-h [HOST]	Module IP address
-p [PORT]	Module Port number
-w 0-4228250625	Set counter
-r	Read counter
-l	Enabled display of additional info

Examples:

Read input state module address 192.168.111.15 listening on port 9761:

```
./tcprel -i 1 -h 192.168.111.15 -p 9761 -l
```

Reset counter :

```
./tcprel -h 192.168.111.15 -p 9761 -i 1 -w 0
```

Set counter 1 to value of 123:

```
./tcprel -h 192.168.111.15 -p 9761 -i 1 -w 123
```

Read state of counter 1:

```
./tcprel -h 192.168.111.15 -p 9761 -i 1 -r
```

6.10 Managing the module using MODBUS TCP

MODBUS TCP protocol is listening on port 502.

The module supports following functions of MODBUS protocol:

- 0x01 Read Coils,
- 0x03 Read Holding Register,
- 0x05 Write Single Coil,
- 0x06 Write Single Register,
- 0x0F Write Multiple Coils,
- 0x10 Write Multiple Registers.

The registers description is shown in tables 2 and 3.

MODBUS TCP - Holding Registers.

Register	Name	Mode: R-read W-write	Description
4003	Counter1H	R/W	Counter 1 – Higher byte of counter
4004	Counter1L	R/W	Counter 1 – Lower byte of counter

MODBUS TCP - Coils

Register	Name	Mode: R- read W-write	Description
1000	On1	R	Input 1 state

6.11 Communication via the MQTT Inveo protocol.

If the MQTT Inveo service has been enabled in the **Administration** menu, the module sends to mqtt.inveo.com.pl server the state of the input every 1 minute and additionally at each change.

Application configuration - MQTT client:

Address: mqtt.inveo.com.pl

Port: 1883

User name: nanouser

User password: nanouser

Topic: /nanoT/<MAC>

After click [\[Show Info\]](#) the settings for the MQTT client will be displayed:

The screenshot shows the 'Administration' page of the Inveo Nano In SV:1.11. The page title is 'Administration' and the subtitle is 'This page allows the configuration of the device's access settings.' The main content area contains several sections:

- Current Password:** [input field]
- New Password:** [input field]
- Re-type Password:** [input field]
- Checkboxes for enabling various protocols:
 - Enable Program Access
 - Enable MODBUS TCP Protocol
 - Enable SNMP
 - Enable Destination Client
 - Enable MQTT Inveo [\[Show Info\]](#)
- MQTT Client Configuration:**
 - Server: mqtt.inveo.com.pl
 - Port: 1883
 - Username: nanouser
 - Password: nanouser
 - Topic: /nano1/5410ec65882b/
- Checkboxes for enabling remote network config and TFTP bootloader:
 - Enable Remote Network Config
 - Enable TFTP Bootloader
- Save Config** button

Copyright © 2015 [Inveo s.c.](#)

There are many applications on Android, IOS or PC that can display data sent by the module.

6.12 Communication with module using HTTP.

NANO modules can be controlled using HTTP get.

- **status.xml** -resource containing basic information about the module

To read the current state of the module, you can refer to the resource in the web browser- <http://192.168.111.15/stat.php>

XML file consist all of the information:

```
<response>
<prod_name>Nano-0-1</prod_name>
<sv>1.11</sv>
<mac>54:10:EC:65:88:2B</mac>
<out>00000000</out>
<on>00000000</on>
<in>00000000</in>
<counter1>35</counter1>
<temp1>0.0</temp1>
</response>
```

Section	Description
<prod_name>Nano-0-1</prod_name>	Module type In this case Nano-0-1.
<sv>1.11</sv>	The software version of the module
<mac>54:10:EC:65:88:2B</mac>	MAC address of the module. Unique for each device.
<out>00000000</out>	In the Nano Digital Input module always 0
<on>00000000</on>	In the Nano Digital Input module always 0
<in>00000001</in>	Input state
<counter1>35</counter1>	Counter state
<temp1>0.0</temp1>	In the Nano Digital Input module always 0

Example:

Set counter 1 to 500

<http://192.168.111.15/stat.php?cnt=1,500>

Reset Counter1

<http://192.168.111.15/stat.php?cnt=1,0>

Reading the input status:

```
curl -u admin:admin00 "http://192.168.111.15/stat.php" -w "\n" 2>/dev/null | grep 'in' | awk -F "[><]" '/in/{print $3}' | cut -c8
```

```
192.168.0.101 - PuTTY
root@debian:~# curl -u admin:admin00 "http://192.168.111.15/stat.php" -w "\n" 2>/dev/null | grep 'in' | awk -F "[><]" '/in/{print $3}' | cut -c8
0
root@debian:~#
```

Reading the counter:

```
curl -u admin:admin00 "http://192.168.111.15/stat.php" -w "\n" 2>/dev/null | grep 'counter1' | awk -F "[><]" '/counter1/{print $3}'
```

```
192.168.0.101 - PuTTY
root@debian:~# curl -u admin:admin00 "http://192.168.111.15/stat.php" -w "\n" 2>/dev/null | grep 'counter1' | awk -F "[><]" '/counter1/{print $3}'
243
root@debian:~#
```

Setting the counter:

```
curl -u admin:admin00 "http://192.168.111.15/stat.php?cnt=1,123"
```

```
192.168.0.101 - PuTTY
root@debian:~# curl -u admin:admin00 "http://192.168.111.15/stat.php?cnt=1,123"
<?xml version="1.0" encoding="iso-8859-1"?>
<response>
<prod_name>Nano-0-1</prod_name>
<sv>1.11</sv>
<mac>54:10:EC:65:88:2B</mac>
<out>00000000</out>
<on>00000000</on>
<in>00000000</in>
<counter1>123</counter1>
<temp1>0.0</temp1>
</response>
root@debian:~#
```

Resetting the counter:

curl -u admin:admin00 "http://192.168.111.15/stat.php?cnt=1,0"

```
192.168.0.101 - PuTTY
root@debian:~# curl -u admin:admin00 "http://192.168.111.15/stat.php?cnt=1,0"
<?xml version="1.0" encoding="iso-8859-1"?>
<response>
<prod_name>Nano-0-1</prod_name>
<sv>1.11</sv>
<mac>54:10:EC:65:88:2B</mac>
<out>00000000</out>
<on>00000000</on>
<in>00000000</in>
<counter1>0</counter1>
<temp1>0.0</temp1>
</response>
root@debian:~#
```

6.13 Communication protocol description

Byte	1	2	3	4	5	6	7	8	9	10	11		
Name	SOF	CMD	CH	Data 1	Data 2	Data 3	Data 4	Data 5	Data 6	Data 7	CRC	Return	
Command													
Set output	15	1	0-7	Mode [1-3]*	ON/OFF [0,1]	TON LSB*	TON MSB*	TOFF LSB*	TOFF MSB*	Restart state**	CRC	ON or NO	
Read channel parameters	15	2	0-7	x	x	x	x	x	x	x	CRC		
Set counter	15	10	0-7	[0:7]	[8:15]	[16:23]	[24:31]				CRC		
Read counter	15	11	0-7	[0:7]	[8:15]	[16:23]	[24:31]				CRC		
WWW control	15	99	x	1 - status 0x55 - off all other - on	x	x	x	x	x	x	CRC	ON or NO	
Read channels	15	100	x	x	x	x	x	x	x	x	CRC	CH7-CH0	Chx - 2 bytes; 1 output state 2 coil state
Read channel name	15	101	0-7	x	x	x	x	x	x	x	CRC	String	
Read device name	15	200	x	x	x	x	x	x	x	x	CRC	String	

*only Lantick and PE-2-1

** only Lantick

*** - Reading parameters returns:

SOF	CMD	Ch	Data 1	Data 2	Data 3	Data 4	Data 5	Data 6	Data 7	CRC
15	2	0-7	Mode[1-3], 100-input	ON/OFF[0,1]	TON LSB	TON MSB	TOFF LSB	TOFF MSB	Restart state	CRC

Description	Value	State
ON/OFF	0	off
	1	on
MODE	1	static
	2	toggle
	3	1-pulse
CRC	Byte sum	

As default modules are listening on port 9761

Frame examples:

Enabling output 1 in static mode

SOF	CMD	CH	Data 1	Data 2	Data 3	Data 4	Data 5	Data 6	Data 7	CRC
15	1	0	0	1	1	0	0	0	0	18

Set counter 2 to 100

SOF	CMD	CH	Data 1	Data 2	Data 3	Data 4	Data 5	Data 6	Data 7	CRC
15	10	1	100	0	0	0	0	0	0	132

6.14 Communication with module from outside network

If the module is in the LAN network different than PC that connects to it, the redirection of ports is necessary.

Depending on the form of communication different ports need to be redirected:

Using web interface:

- port TCP/IP 80

Computer software or customer application:

- port TCP/IP 9761

Using MODBUS TCP protocol:

- port TCP/IP 502

Using SNMP protocol:

- port UDP 161

7 Checking the IP address

To check the current IP address of the device:

1. Press and hold the reset button until the display shows the four parts of the IP number, e.g.

192
168
111
15

2. Release the reset button.

8 DHCP

To enable/disable DHCP service:

1. Press and hold RESET button until the display shows: **dhcP**
2. Release the reset button.
3. Depending on the current DHCP setting, the message will be displayed **-on** or **-oFF**

9 Restoring factory defaults

In order to restore the module to its factory defaults:

1. Press and hold reset button until the display shows: **rSt**
2. Release the reset button.

With factory defaults restored the module settings are as follows:

- IP address : 192.168.111.15
- IP mask : 255.255.255.0
- User name : admin
- Password: admin00

10 Firmware update

The module has the ability to update the firmware. The firmware is supplied as a file with .bin extension.

Note! Improper use of the update feature may damage the module. Make sure that undisturbed power is connected to the module for duration of programming.

To perform the programming operation, go to the Windows command line (Start-> Run-> type 'cmd' and confirm with Enter).

Then navigate to the directory where the file resides and enter the command

```
tftp -i <module_ip_adress> PUT filename.bin
```

where: < module_ip_adress > is the IP address of the module
filename.bin – is the firmware supplied by Inveo s.c.

The programming takes about 1 minute and it's confirmed by "File Transferred" message.

